

# CVMX-500AW/25-BEAA-J

Old Type Designation: CV1W-500K

## Specifications

Capacity $C_{max}$ (nominal)	500 pF
Capacity $C_{min}$ (nominal)	50 pF
Voltage (Peak Test $U_{pt}$ / Peak Working $U_{pw}$ )	25 kV / 15 kV
Capacity Tolerance (linear Range)	10%
Max. Current $I_{max}$ at 13.56 MHz with	182 Arms
Water Cooling	0.5 l/min
Self Inductance	$\leq 7$ nH
Capacitance per turn	23.4 pF/turn
Torque	$\leq 0.6$ Nm
Net Weight	2.7 kg

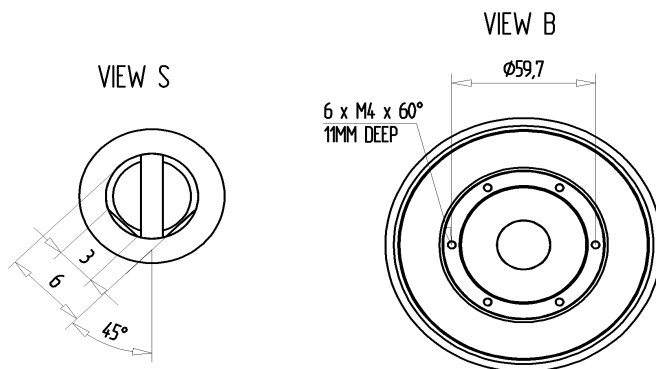
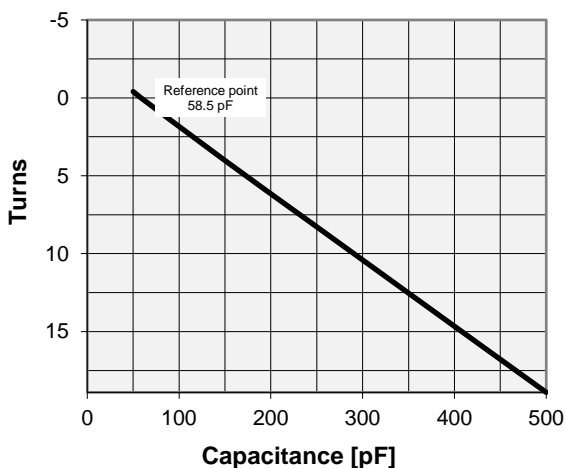
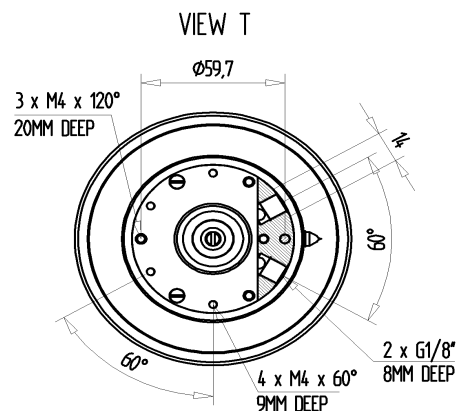

$I_{max}$  for 0.5 l/min water cooling; max. water temp. at inlet: 70°C

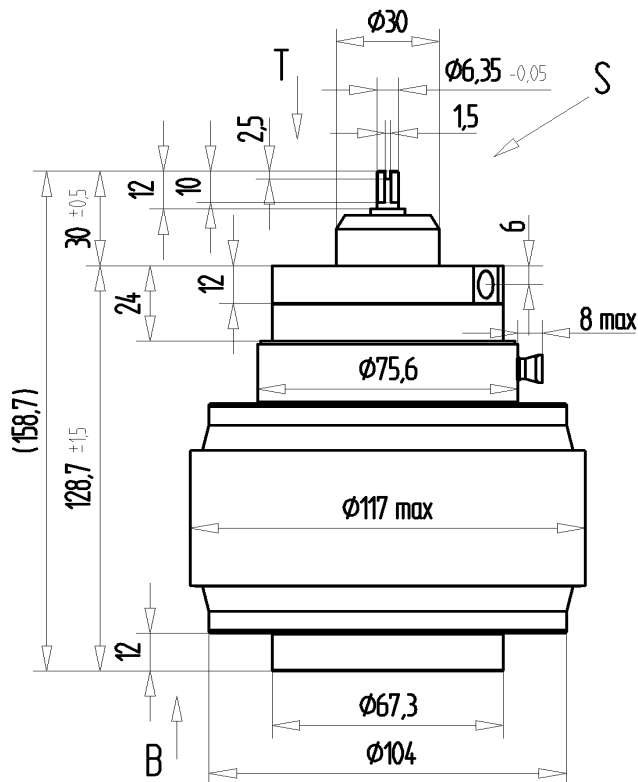
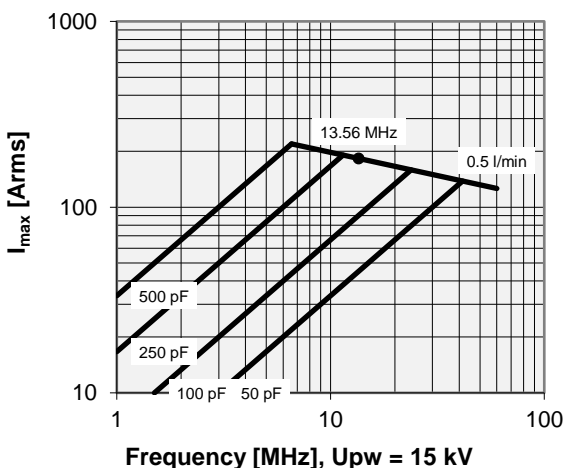

Note:  
 Technical information in Service Bulletin  
 SB-52 must be considered  
 Subject to change without prior notice

Issue: 14-Feb-2008  
 Replaces: 09-Jun-2005  
 pct.comet.tech

# CVMX-500AW/25-BEAA-J

Old Type Designation: CV1W-500K

Turns	Nominal Capacitance [pF]	Tolerance
-0.4	50.0	10%
-0.2	54.3	10%
0.0	58.5	0%
4.0	149.5	10%
8.0	243.5	10%
12.0	337.5	10%
16.0	431.6	10%
18.9	500.0	10%

Mechanical stop at < 50 pF at ~ -2.9 turns  
 Mechanical stop at > 500 pF at ~ 19.1 turns

Self inductance and resonance frequency

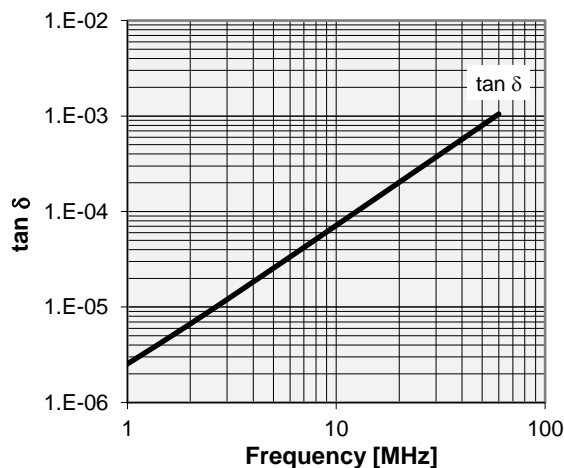
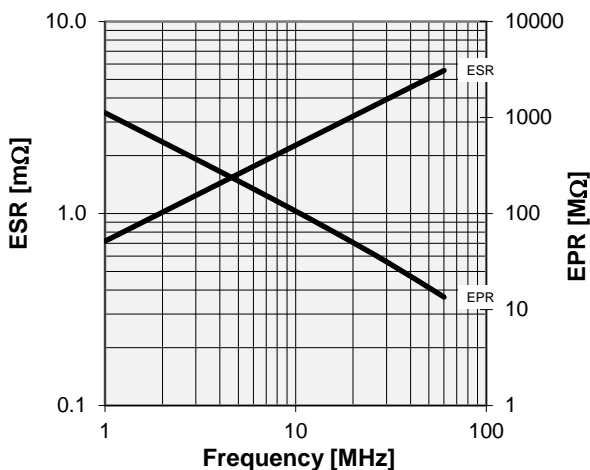
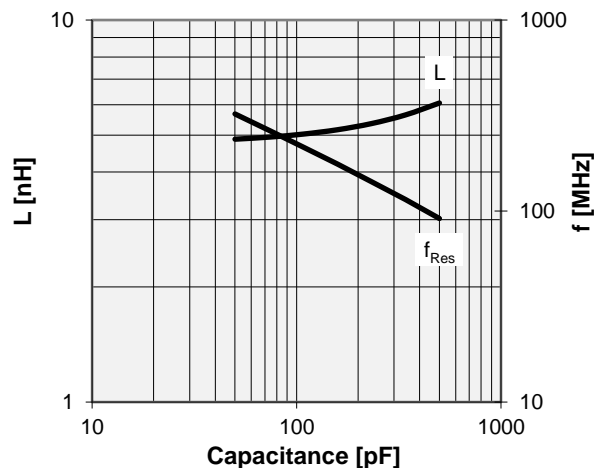

<b>Special Features:</b>
Special Bellows

Note:  
 Technical information in Service Bulletin  
 SB-52 must be considered  
 Subject to change without prior notice