

MGS MAX-GAIN SYSTEMS, INC.

150 Dodd Street SE
Marietta, GA. 30060

Phone: 770-973-6251
Fax: 678-401-3854

Email: info@mgs4u.com
Website: www.mgs4u.com



Installation Guide

[HN male Clamp Connector for .405 Coax](#)

We will begin by installing the HN male clamp connector on a piece of LMR-400. This process is the same for all the other types of cable with an outer jacket OD of 0.405. These connectors fit on a wide range of coax types including, but not limited to: RG-8, RG-11, RG-83, RG-213, RG-393, LMR-400, Belden 8237, Belden 8267, Belden 9011, and Belden 9913.

Identify All Components:

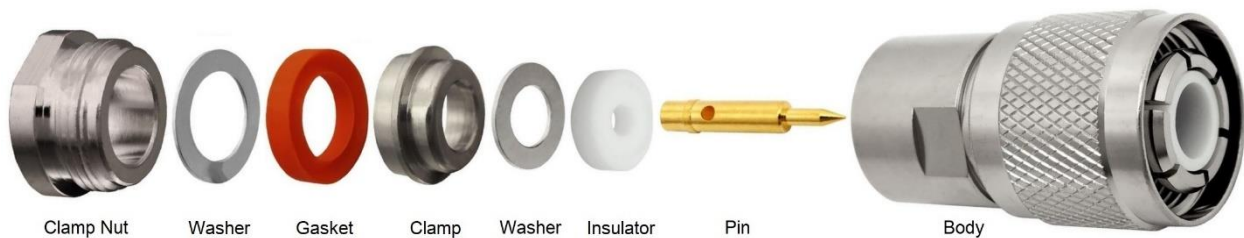

Coax Stripping:

First cut your cable to the desired length and place the “clamp nut”, “washer” and “gasket” then strip the black jacket back approximately 0.37 inches / 9.5 mm.

Step 1

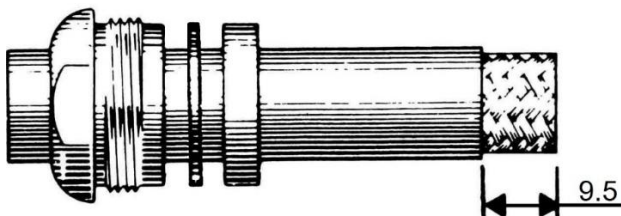

Comb out the braid and fan it out so you can get to the dielectric. Trim back the dielectric 0.25 inches / 6.4 mm.

Step 2

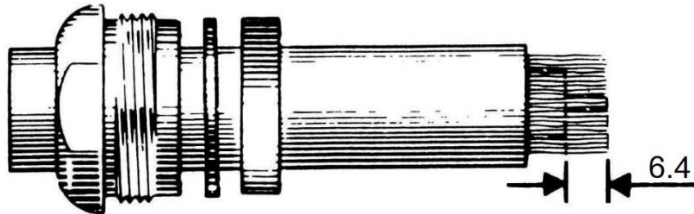

Pull the braid wires forward and taper them toward the center conductor. Place the clamp nut onto the coax by threading the braid through the center and push the clamp nut against the jacket as shown.

Step 3

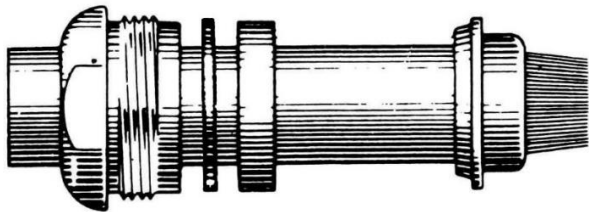

Fold back the braid wires as shown below and trim the braid so it does not go over the flange of the clamp nut. Solder the center pin onto the center conductor of the coax.

Solder-On Method

Make sure the solder hole is facing up. Touch the soldering iron to the underside of the center pin directly under the solder hole. Touch the solder to the center conductor through the solder hole on the center pin. Allow the heat from the metal to melt the solder so that it wicks into the center pin. Once the solder melts it only takes a tiny amount of solder to make the connection. Do not allow the solder to pool over the solder hole. The outside of the center pin should be free of obstructions for insertion. Do not over heat the center pin which could cause swelling of the dielectric of the coax.

Step 4

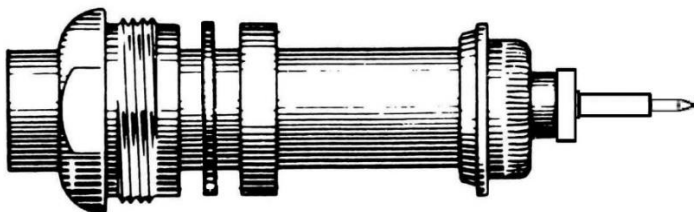

Main Body Install:

Insert the cable and all of the parts into the connector body. Make sure that the gasket's inner "V" channel goes correctly into the clamp nut. Tighten the back nut.

Step 5

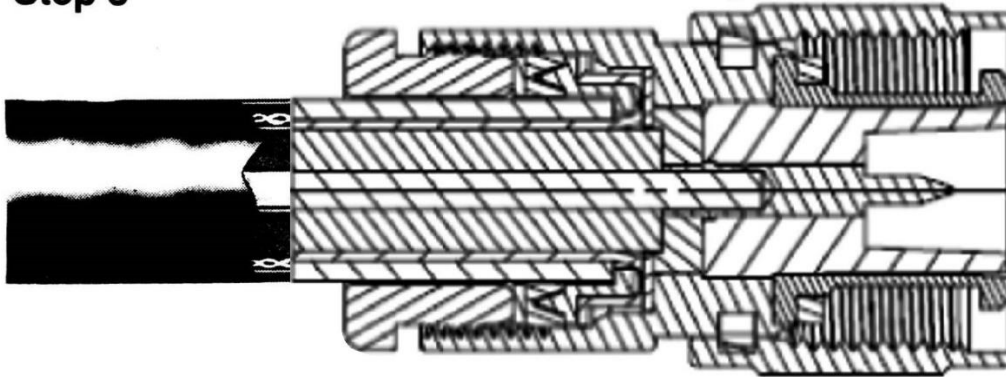

Final Testing:

When this is completed, as a final test, you should always check resistance from the center pin to the body with an ohmmeter in a low resistance scale. After verifying that there are no braid – to – center pin shorts on the other end of the coaxial cable, you should see infinite resistance (open). Click the following link to obtain additional information including price, inventory, and certifications: <https://mgs4u.com/product/hn-male-clamp-connector-for-rg-8-rg-11-rg-83-rg-213-rg-393-lmr-400-and-other-0-405-inch-od-coax-8305-hn-cn-400/>

