

CVBA-170BC/15-BUA-L

Old Type Designation: CV1C-170FL

Specifications

Capacity C_{max} (nominal)	170 pF
Capacity C_{min} (nominal)	5 pF
Voltage (Peak Test U_{pt} / Peak Working U_{pw})	15 kV / 9 kV
Capacity Tolerance (linear Range)	10%
Max. Current I_{max} at 13.56 MHz with	64 Arms
Conduction Cooling	10 W
Self Inductance	≤ 9 nH
Capacitance per turn	9.3 pF/turn
Torque	≤ 0.15 Nm
Net Weight	0.6 kg

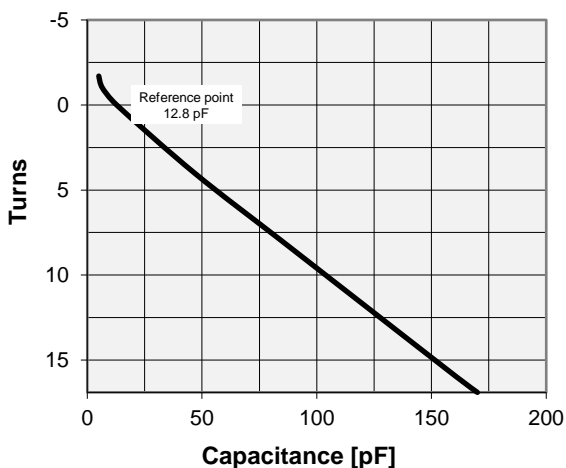

I_{max} at 25°C ambient and 125°C surface temp. for convection and conduction (10 W) cooling

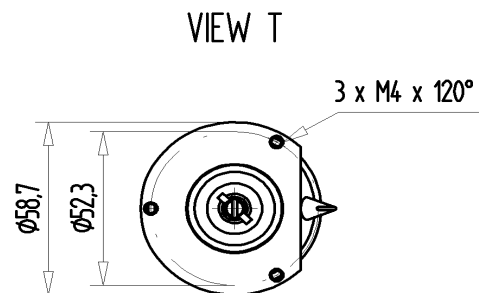
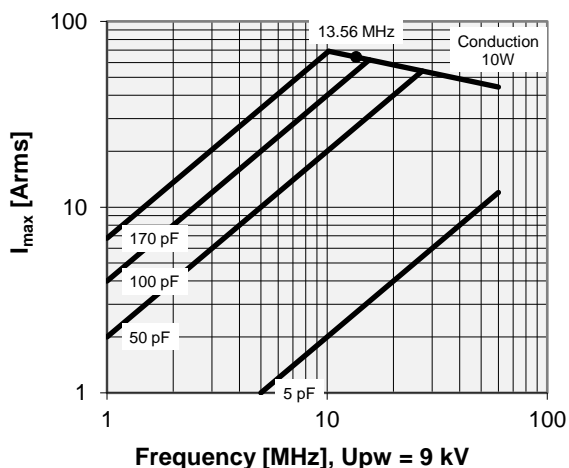

VIEW B

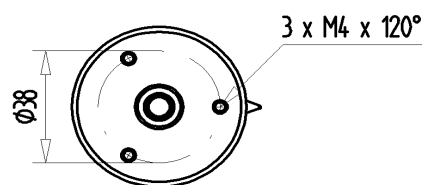

VIEW S

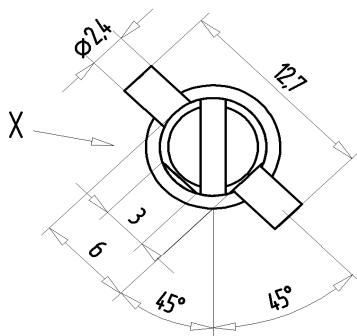

VIEW X

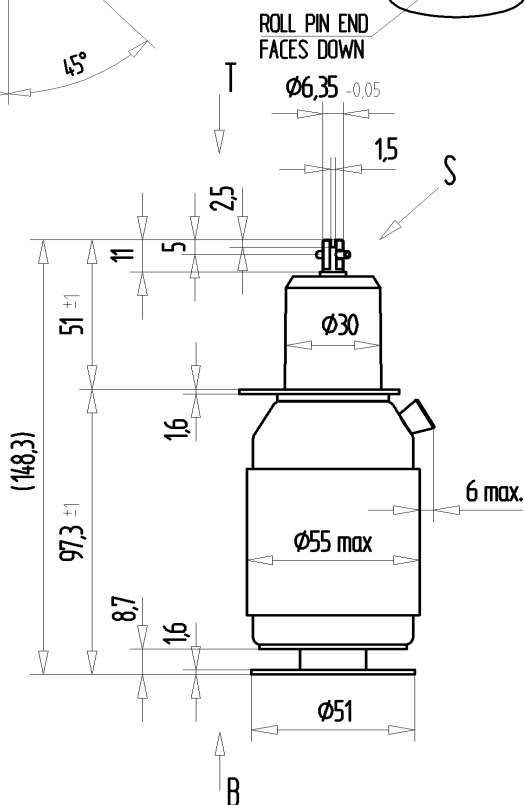
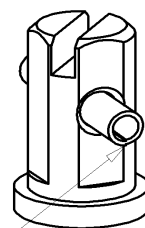

Note:
 Technical information in Service Bulletin
 SB-52 must be considered
 Subject to change without prior notice

CVBA-170BC/15-BUA-L

Old Type Designation: CV1C-170FL

Turns	Nominal Capacitance [pF]	Tolerance
-1.7	5.0	10%
-1.0	6.6	10%
0.0	12.8	0%
4.0	46.7	10%
8.0	84.8	10%
12.0	122.9	10%
16.0	161.0	10%
16.9	170.0	10%

Mechanical stop at < 5 pF at ~ -6 turns
 Mechanical stop at > 170 pF at ~ 17.3 turns

Self inductance and resonance frequency

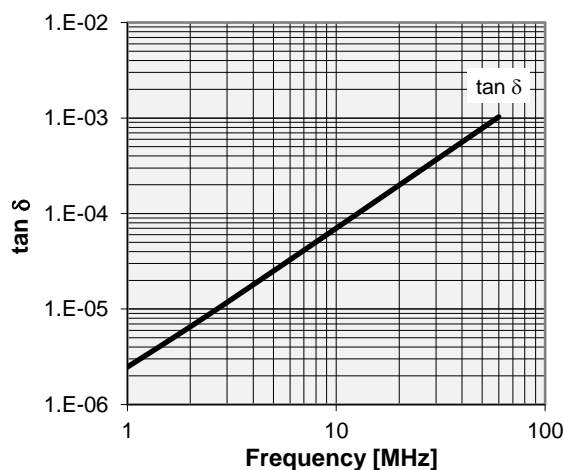
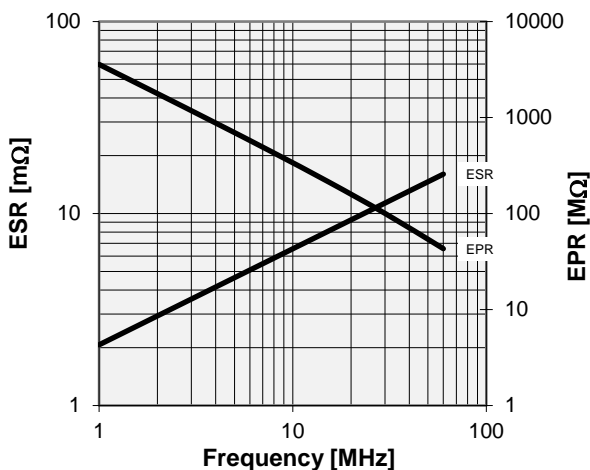
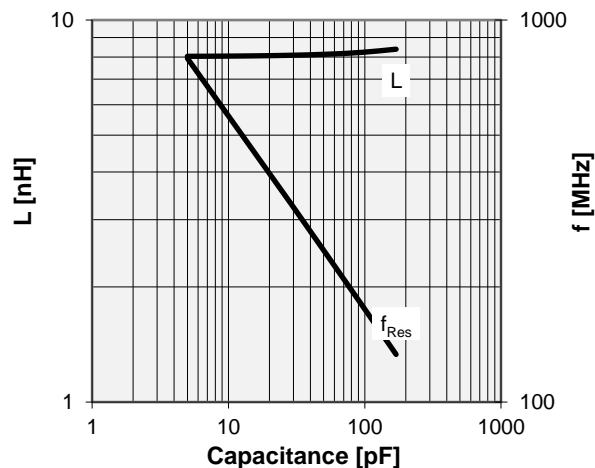

Special Features:
Integrated Flange

Note:
 Technical information in Service Bulletin
 SB-52 must be considered
 Subject to change without prior notice