

V23

- Durable tungsten contacts for better load switching capability
- Ideal choice for high power RF or DC applications
- Solder or threaded mounting options

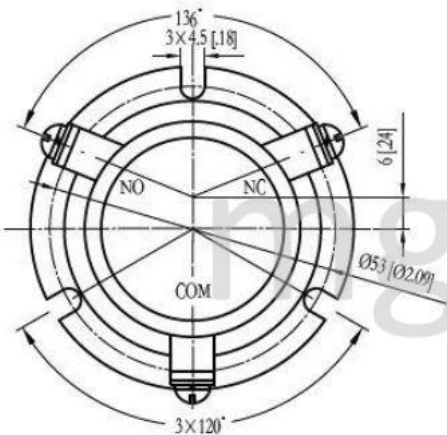

Wiring Diagram

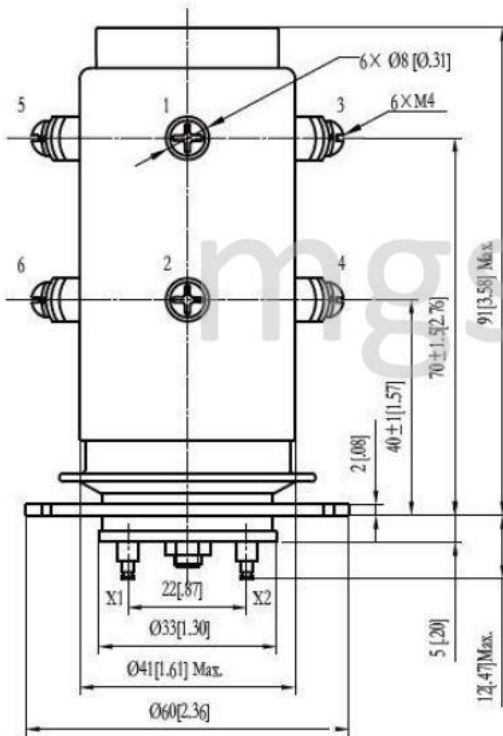
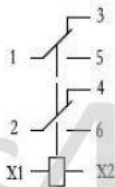

Coil Terminals X1&X2
Not Polarity Sensitive

Vertical installation

※ : Order the relay with the coil voltage in the part number as shown above. The coil voltage will appear on the coil plate near the coil terminals rather than in the pin on the relay.

※ ※ : Consult factory for load switching applications.

PRODUCT SPECIFICATIONS

| Item | Unit | Value | |
|---|----------------------|----------------------|---------|
| Contact Form | — | 2C | |
| Contact Arrangement | — | DPDT | |
| Contact Material (moveable/stationary) | — | molybdenum /tungsten | |
| Dielectric | | Vacuum | |
| Maximum Peak Test Voltage, Contacts and to Base (15µA Leak Current Max.) dc or 60Hz | kV | 23 | |
| Maximum Peak Operating Voltage, Contacts and to Base (15µA Leak Current Max.) | dc or 60Hz | kV | 20 |
| | 2.5MHz | kV | 12 |
| | 16MHz / 32MHz | kV | 8 / 5 |
| Current, Load Switching ※ ※ | | Contact factory | |
| Current, Continuous Carry Max | dc or 60Hz | A | 75 |
| | 2.5MHz | A | 35 |
| | 16MHz / 32MHz | A | 22 / 15 |
| Coil Hi-Pot (V RMS, 60 Hz) | V | 500 | |
| Capacitance | Across Open Contacts | pF | 3 |
| | Contacts to Ground | pF | 3.5 |
| Operate Time | ms | 30 | |
| Release Time | ms | 10 | |
| Resistance, Contact Max @ 1A, 28 Vdc | Ω | 0.01 | |
| Operating Temperature Ambient | °C | -55 ~ +125 | |
| Shock, Operating, 1/2 Sine 11ms (Peak) | G's | 50 | |
| Vibration, Operating, Sine (55-500 Hz Peak) | G's | 10 | |
| Life, Mechanical | Cycles | 1 million | |
| Weight, Nominal | g(oz) | 360(12.7) | |

COIL RATINGS

| | | |
|---|------|------|
| Nominal, Volts dc | 12 | 26.5 |
| Pick-up, Volts dc, Max. | 8 | 16 |
| Drop-Out, Volts dc | .5~5 | 1~10 |
| Coil Resistance (Ω ±10%) | 60 | 240 |
| Ratings Listed are for 25°C, Sea Level Conditions | | |

PART NUMBER SYSTEM

Series: High Voltage/Power **V23 — W F — 12 Vdc**

Terminal Connections

Contact Leads Out: W=Screw

Mounting: F=Flange

Coil Voltage ※: Blank=26.5Vdc, —12Vdc=12Vdc