

FEATURES

- > Tungsten contacts for better load switching performance**
- > Vacuum dielectric allows for make and/or break load switching
- > Mounting options in any axis
- > Threaded HV connections means easy installation



PRODUCT SPECIFICATIONS

Contact & Relay Ratings	Units	G32
Contact Form		Y
Contact Arrangement		SPST-NC
Contact Material (moveable/stationary)		molybdenum /tungsten
Dielectric		Vacuum
Voltage, Test Max., Contacts & to Base (15 µA Leakage Max., dc or 60Hz)	kV Peak	28
Voltage, Operating Max., Contacts & to Base (15 µA Leakage Max.) dc or 60 Hz	kV Peak	25
Current, Load Switching		Contact Factory**
Current, Continuous Carry Max dc or 60 Hz	Amps	45
Coil Hi-Pot (V RMS, 60 Hz)	V	500
Capacitance		
Across Open Contacts	pF	2.5
Contacts to Ground	pF	2.5
Resistance, Contact Max @ 1A, 28 Vdc	ohms	0.01
Operate Time	ms	18
Release Time	ms	20
Life, Mechanical	cycles	2 million
Weight, Nominal	g (oz)	342 (12)
Vibration, Operating, Sine (55-500 Hz Peak)	G's	10
Shock, Operating, 1/2 Sine 11ms (Peak)	G's	30
Temperature Ambient Operating	°C	-55 to +125

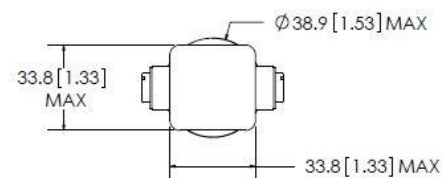
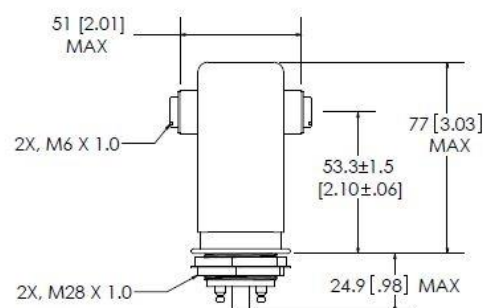

PART NUMBER SYSTEM

G32	W	P	
High Voltage/ Power Terminal Connections	W= Screw		
Mounting		P = Through Panel	
Coil Voltage*			Blank = 26.5 Vdc -12Vdc = 12 Vdc -115Vdc = 115 Vdc

COIL RATINGS

Nominal, Volts dc	12	26.5	115
Pick-up, Volts dc, Max.	8	16	80
Drop-Out, Volts dc	.5 - 5	1 - 10	5 - 50
Coil Resistance (Ohms ±10%)	24	120	2000

* Order the relay with the coil voltage in the part number as shown above. The coil voltage will appear on the coil plate near the coil terminals rather than in the P/N on the relay.

** Consult factory for load switching applications