



150 Dodd Street SE
Marietta, GA. 30060

Phone: 770-973-6251
Fax: 678-401-3854

Email: info@mgs4u.com
Website: www.mgs4u.com

UHF male Quick Connect Crimp On for LMR-195, LMR-200, RG-142, RG-142B/U, RG-141, RG-141A/U, RG-142A/U, RG-122/U, RG-400, RG-400/U, RG-58, RG-55, RG-55B/U, RG-55A/U, RG-58C/U, RG-223, RG-223/U, and other 0.195 Inch OD Coaxial Cable.



Technical Data Sheet

This UHF Male Quick Connect Crimp Connector is one of several thousand RF products available from Max-Gain Systems, Inc. This connector has a crimp on interface with the coax selected.

This quick connect connector is made from a Solid Brass body that is precision machined and plated with Silver for superior performance and value. This UHF Male Quick Connect Crimp Connector has a PTFE dielectric and a silver plated brass center pin. The UHF Male interface (also known as a PL-259 connection) is by far the most popular connection type used in Amateur Radio. This RF connector fits (but not limited to) LMR-195, LMR-200, RG-142, RG-142B/U, RG-141, RG-141A/U, RG-142A/U, RG-122/U, RG-400, RG-400/U, RG-58, RG-55, RG-55B/U, RG-55A/U, RG-58C/U, RG-223, RG-223/U, and other 0.195 Inch OD Coaxial Cable.

Material Specifications

UHF male, QC, Crimp-On, Cable End Connector for .195 Coax **P/N 7505-QC-K58**

Description	Material	Plating
Ferrule	Brass	Silver
Pin	Brass	Silver
Shell	Brass	Silver
Insulator	PTFE	White
Body	Brass	Silver

Mechanical Specifications

Size	Dimension
Length	1.2 in (30.6 mm)
Width	0.72 in (18.2 mm)
Height	0.72 in (18.2 mm)
Weight	0.8 oz (24 g)

Environmental Specifications

Temperature	Spec
Operating Range	-65 to +165 deg C

Compliance Certifications (see product page for current documentation)

Availability Click the following link (or enter part number in the “SEARCH” bar at the top of any page of the website) to obtain additional part information including price, inventory and certifications: <https://mgs4u.com/product/uhf-male-quick-connect-crimp-connector-for-0-195-inch-od-coax-7505-gc-k58/>

5/8-24UNEF-2B

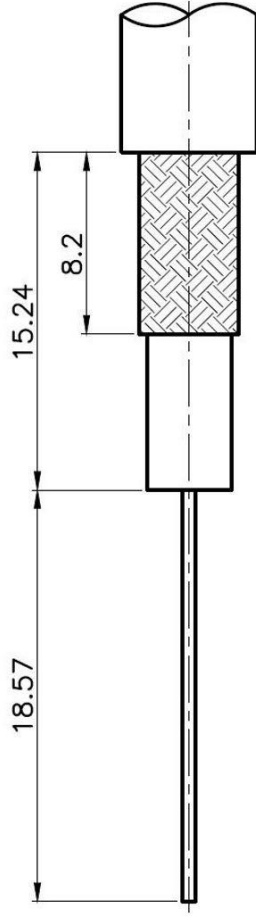
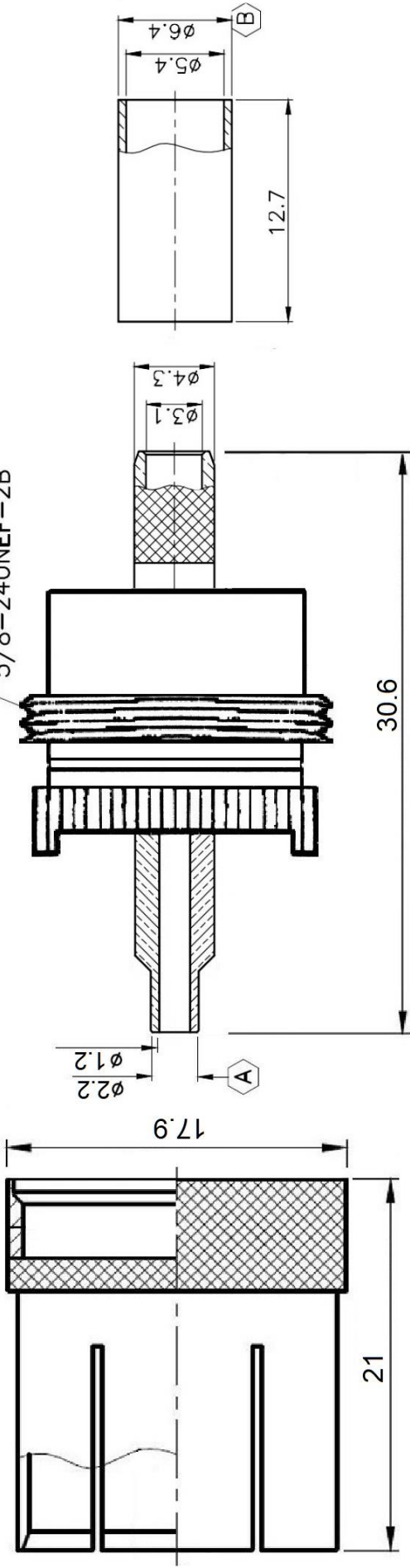

.213

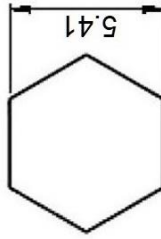

Die Size B

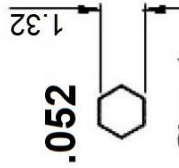

.052

Die Size A

RECOMMENDED
CABLE STRIPPING DIM'S

MGS MAX-GAIN SYSTEMS, INC.

Max-Gain Systems, Inc.
150 Dodd Street SE, Marietta, GA. 30060
Phone: (770) 973-6251 | Fax: (678) 401-3854
Website: www.mgs4u.com | E-Mail: sales@mgs4u.com

TITLE: UHF male Quick Connect Crimp
Connector for 0.195 Inch OD Coax

DRAWING NO: 7505-QC-K58

FILE NO :

PART NO	DATE	UNLESS OTHERWISE SPECIFIED TOLERANCES	UNIT: mm	QTY
APPROVED	DATE	0.5-5 = ±0.2		
CHECKED	DATE	5-30 = ±0.4		
DRAWN	DATE	30-120 = ±0.6		
		120-315 = ±1		
		315-1000 = ±1.6		
		1000-2000 = ±2.4		
			SCALE: .	
FERRULE		BRASS	SILVER	
SHELL		BRASS	SILVER	
PIN		BRASS	SILVER	
INSULATOR		TEFLON	WHITE	
BODY		BRASS	SILVER	
NO. DESCRIPTION		MATERIAL	FINISH	

Installation Guide

We will begin by installing the UHF male crimp-on connector on a piece of coax. This process is the same for all the types of coaxial cable that fit this UHF crimp-on connector. These connectors fit on a wide range of coax types, including: LMR-195, LMR-200, RG-142, RG-142B/U, RG-141, RG-141A/U, RG-142A/U, RG-122/U, RG-400, RG-400/U, RG-58, RG-55, RG-55B/U, RG-55A/U, RG-58C/U, RG-223, RG-223/U, and other 0.195 Inch OD Coaxial Cable.

Identify all connector parts (2 Parts):

Each connector consists of one body assembly (plug), the QC sleeve, and one rear ferrule (crimp sleeve),

Step 1

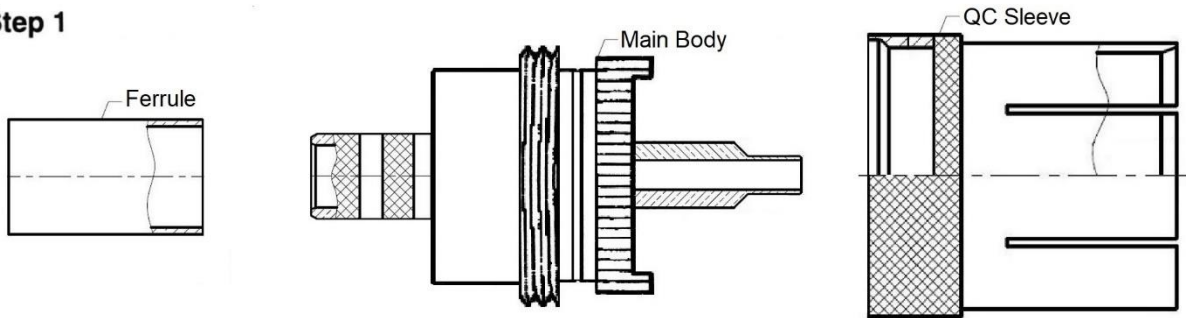

Coax Stripping:

First cut your coaxial cable to the desired length and then strip the black jacket back approximately 33.81mm (1.33"). When the jacket is stripped cut the braid/foil back 25.61mm (1.00") from the fresh cut end. Finally, cut back the dielectric 18.57mm (0.73") from the fresh end down to the center conductor. The braid needs to be cut back further than the dielectric to insure that none of the braid or foil is touching the center conductor which could cause a short.

Once the cable is prepped, **make sure to put the ferrule (crimp sleeve) of the connector on the coaxial cable BEFORE you proceed.**

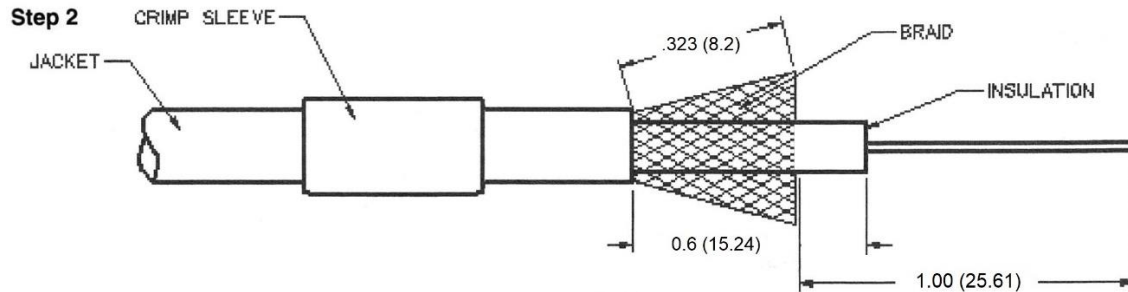

Crimping and Soldering Install:

Soldering Guide (preferred):

This soldering guide is for soldering Max-Gain Systems, Inc. UHF crimp-on connectors. These are approximate measurements for our UHF crimp-on connectors, which adhere to industry standards for this type connector. If you choose to use this guide for connectors sold by others who do NOT adhere to these standards, the measurements could be off and result in a poor installation.

Now we begin by placing the body of the connector onto the end of the coax. Be sure the center conductor goes through the center pin of the connector AND that the braid goes over the knurled section of the connector body. The braid needs to be on the outside of the connector and not tucked under it. This could lead to a short. Trim the excess center conductor with a small pair of diagonal cutters flush with the end of the center pin. Apply heat to the center pin of the UHF connector by placing your soldering iron underneath the pin. Before proceeding, allow sufficient time for the soldering iron tip to reach full operating temperature and clean the tip of the iron by wiping it with a damp sponge. Now apply the solder to the hole tip. The heat rises and heats up the pin faster than positioning the iron above the pin. When the pin is heated the solder will start to flow into the pin. It only takes a little solder to make a good connection. You can apply the solder so that it forms a small bubble / dome on the end of the center pin, but not more than that.

Crimping Guide:

The center pin is crimpable by using the 0.052" hex die from your 7505-DIE-8X ratcheting crimper die to crimp the smaller tapered portion of the center pin. This crimp die is available by itself or as a kit with a ratcheting crimp handle.

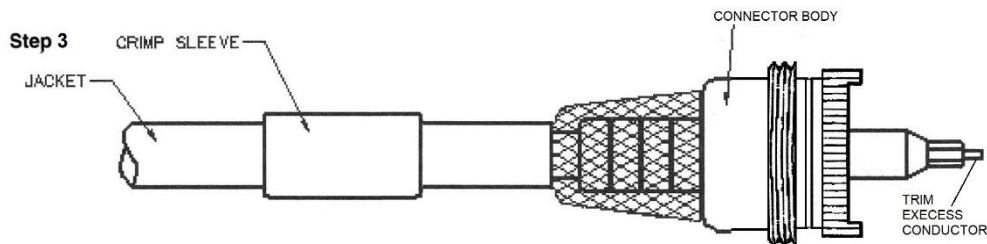

DIE Only	Die and Tool Kit
P/N: 7505-DIE-8X	P/N: 7505-HANDLE-8X
	

Crimping The Ferrule:

Slide the ferrule (placed on the coax at the beginning of Step 2) over the braid and completely up against the connector body. Using the 0.213" hex die from the 7505-DIE-8X installed into the 7505-HANDLE ratcheting crimp handle, crimp the ferrule at the location shown in the picture below (on the ferrule, but right up against the main body of the connector). Finally, screw on the quick connect sleeve.

Step 4

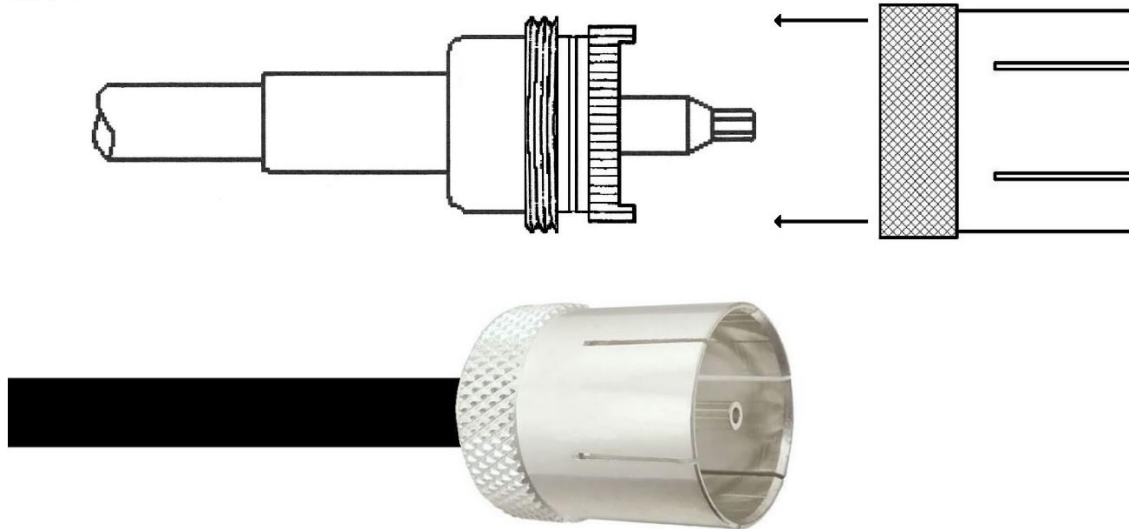

Final Testing:

When this is completed, as a final test, you should always check resistance from the center pin to the body with an ohmmeter in a low resistance scale. After verifying that there are no braid – to – center pin shorts on the other end of the coaxial cable, you should see infinite resistance (open). This completes your UHF male crimp-on connector installation, and the connector is ready for use!