

150 Dodd Street SE
Marietta, GA. 30060

Phone: 770-973-6251
Fax: 678-401-3854

Email: info@mgs4u.com
Website: www.mgs4u.com



Installation Guide

We will begin by installing the BNC crimp-on connector on a piece of coax. This process is the same for all the types of coaxial cable that fit this BNC crimp-on connector. These connectors fit on a wide range of coax types, including: LMR-240, LMR-240 Ultraflex, Mini 8, Micro 8/U, RG-59, RG-8X, Belden 8241, Belden 8221, Belden 9169, Belden 9204, Belden 9228, Belden 9258, Belden 1426A, Belden 1505A, Belden 8212, Belden 8241F, Belden 9100, Belden 9110, Belden 9165, Belden 9171, Belden 9240, Belden 9259, Belden 9265, Belden 9274, Belden 9275, Belden 9659, Belden 8279, Belden 8279A, Belden 9209, Belden 9209A, Belden 82241, Belden 88241, Belden 1506A, Belden 1825A, Belden 1826A, Belden 82108, Belden 89108, Belden 89259, and other 0.240 Inch OD Coax.

Identify all connector parts (3 Parts):

Each connector consists of one body assembly (plug), one rear ferrule (crimp sleeve), and one center pin (plug contact).

Step 1

CRIMP SLEEVE

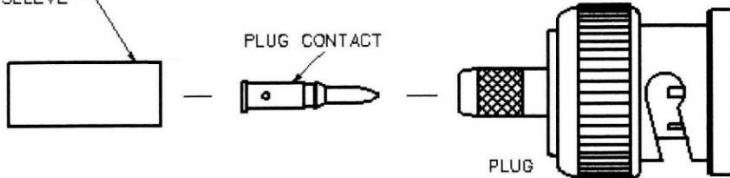

Coax Stripping:

First cut your coaxial cable to the desired length and then strip the black jacket back approximately 15mm (0.59"). When the jacket is stripped cut the braid/foil back 7.2mm (0.28") from the fresh cut end. Finally, cut back the dielectric 3mm (0.12") from the fresh end down to the center conductor. The braid needs to be cut back further than the

dielectric to insure that none of the braid or foil is touching the center conductor which could cause a short.

Once the cable is prepped, make sure to put the ferrule (crimp sleeve) of the connector on the coaxial cable before you proceed.

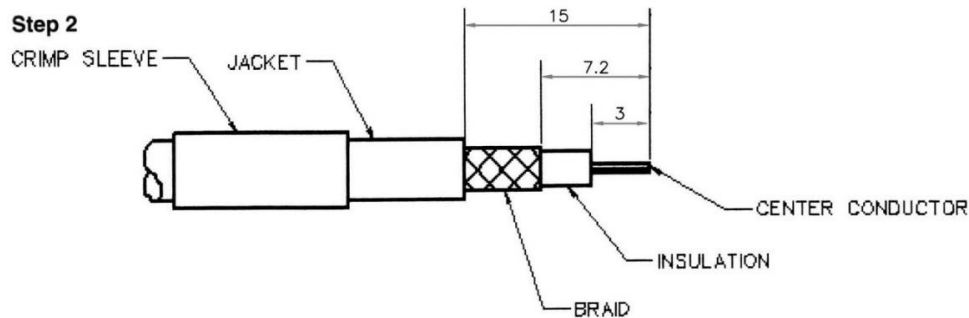

Crimping and Soldering Install:

Place the center pin onto the conductor of the coaxial cable.

Soldering Guide (preferred):

This soldering guide is for soldering Max-Gain Systems, Inc. BNC crimp-on connectors. These are approximate measurements for our BNC crimp-on connectors, which adhere to industry standards for this type connector. If you choose to use this guide for connectors sold by others who do NOT adhere to these standards, the measurements could be off and result in a poor installation.

Now we begin soldering the center pin onto the center conductor of the coax.

Begin by applying heat to the center pin of the BNC connector with your soldering iron. Before proceeding, allow sufficient time for the soldering iron tip to reach full operating temperature and clean the tip of the iron by wiping it with a damp sponge. Place the soldering iron UNDER the center pin and, with the solder hole of the center pin facing up, apply the solder into the hole. The heat rises and heats up the pin faster. When the pin is heated the solder will start to flow into the pin. Allow sufficient solder to flow into the center pin to make a good connection, but not too much that it begins to leak out and potential start to melt the dielectric of the coax.

Crimping Guide:

Use the 0.068" hex die from your 7505-DIE-8X ratcheting crimper die to crimp the center pin above the small lip of the center pin right on top of the "solder hole". This crimp die is available by itself or as a kit with a ratcheting crimp handle.

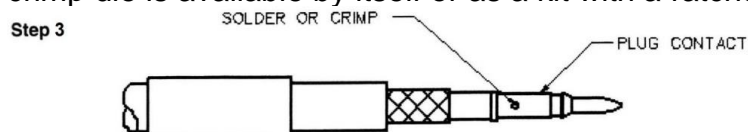

DIE Only	Die and Tool Kit
P/N: 7505-DIE-8X	P/N: 7505-HANDLE-8X
	

Crimping The Ferrule:

Flare out the braid of the coax and slide the body assembly over the center pin and under the braid. Then seat the body assembly firmly onto the center contact. Arrange braid uniformly around the knurled portion of the body assembly. Slide the ferrule (crimp sleeve) forward and make sure it is in contact with the body assembly. Using the 0.255" hex die from the 7505-DIE-8X ratcheting crimper die to crimp the ferrule (crimp sleeve) right up next to the main body assembly. This crushes the metal sleeve around the braid and knurling to make it difficult for the connector to be removed. Trim any braid that extends out from crimp sleeve, against the body assembly, so not have any strays sticking out.

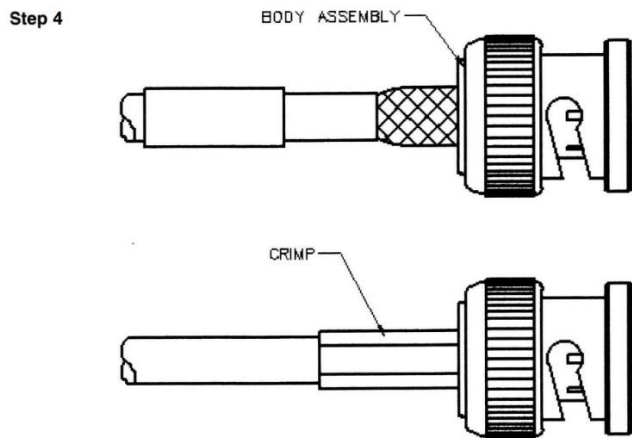

Final Testing:

When this is completed, as a final test, you should always check resistance from the center pin to the body with an ohmmeter in a low resistance scale. After verifying that there are no braid – to – center pin shorts on the other end of the coaxial cable, you should see infinite resistance (open). This completes your BNC male crimp-on connector installation! Click the following link to obtain additional part information including price, inventory and certifications: <https://mgs4u.com/product/bnc-male-crimp-connector-for-0-240-inch-od-coax-7005-bnc-8x/>