

# CVBA-500BC/5-DEA-CL

Old Type Designation: CV05C-500XE

## Specifications

Capacity $C_{max}$ (nominal)	500 pF
Capacity $C_{min}$ (nominal)	5 pF
Voltage (Peak Test $U_{pt}$ / Peak Working $U_{pw}$ )	5 kV / 3 kV
Capacity Tolerance (linear Range)	10%
Max. Current $I_{max}$ at 13.56 MHz with	57 Arms
Conduction Cooling	10 W
Self Inductance	$\leq 9$ nH
Capacitance per turn	29.1 pF/turn
Torque	$\leq 0.15$ Nm
Net Weight	0.6 kg

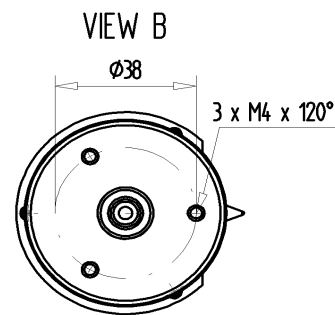
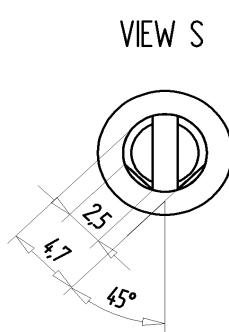
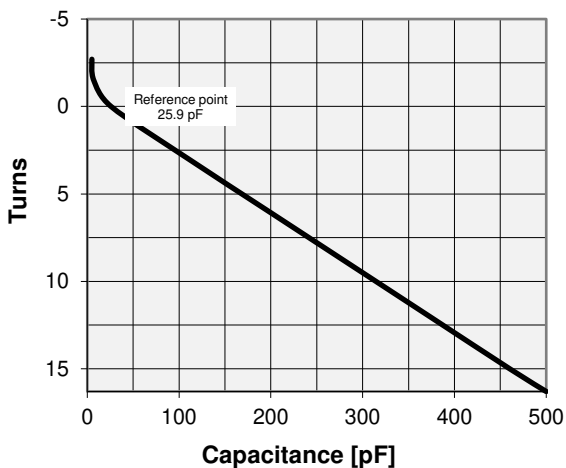
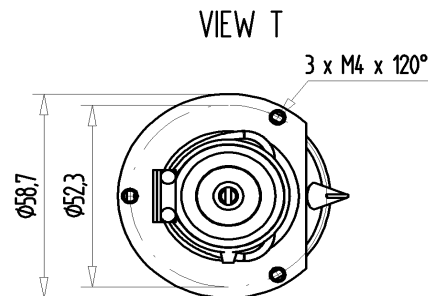

$I_{max}$  at 25°C ambient and 125°C surface temp. for convection and conduction (10 W) cooling

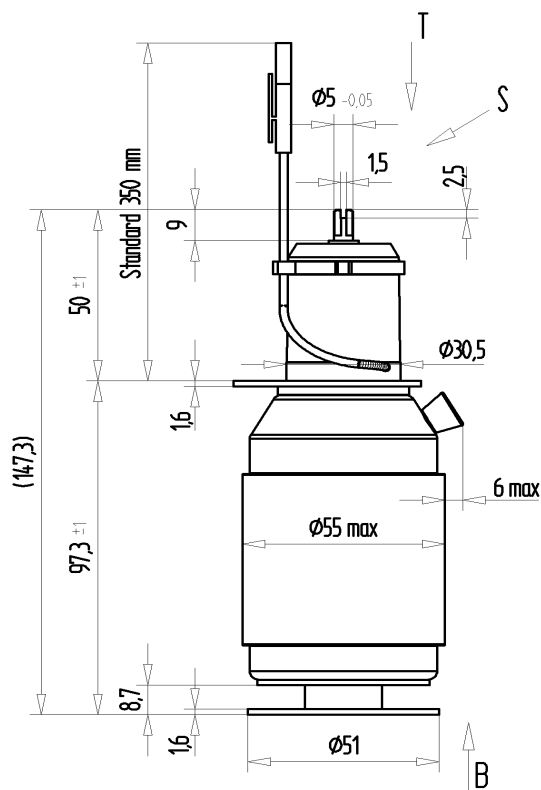
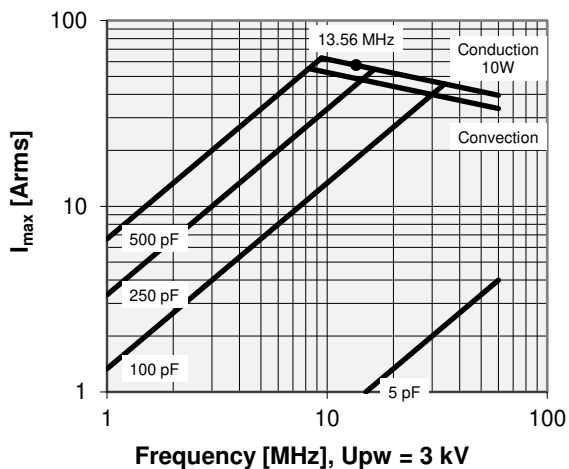

Note:  
 Technical information in Service Bulletins  
 SB-32 and SB-52 must be considered  
 Subject to change without prior notice

# CVBA-500BC/5-DEA-CL

Old Type Designation: CV05C-500XE

Turns	Nominal Capacitance [pF]	Tolerance
-2.7	5.0	10%
-1.5	7.0	10%
0.0	25.9	0%
3.0	110.2	10%
6.0	197.7	10%
9.0	285.2	10%
12.0	372.7	10%
15.0	460.2	10%
16.3	500.0	10%

Mechanical stop at < 5 pF at ~ -6.1 turns  
 Mechanical stop at > 500 pF at ~ 16.6 turns

Self inductance and resonance frequency

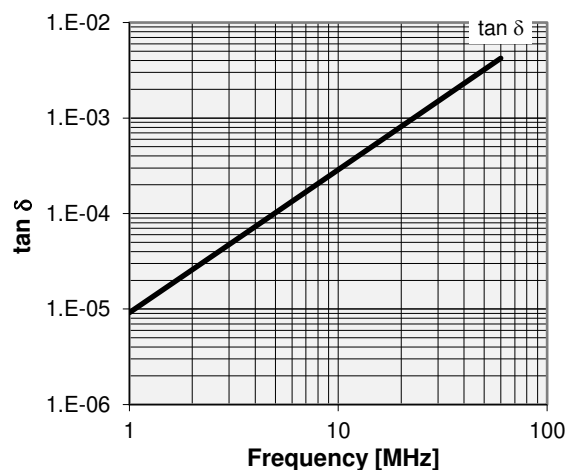
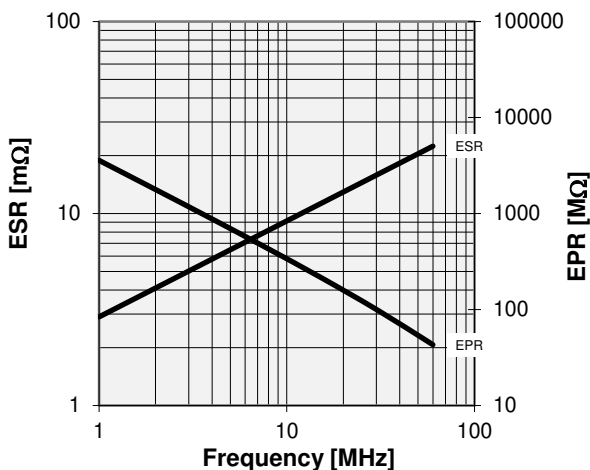
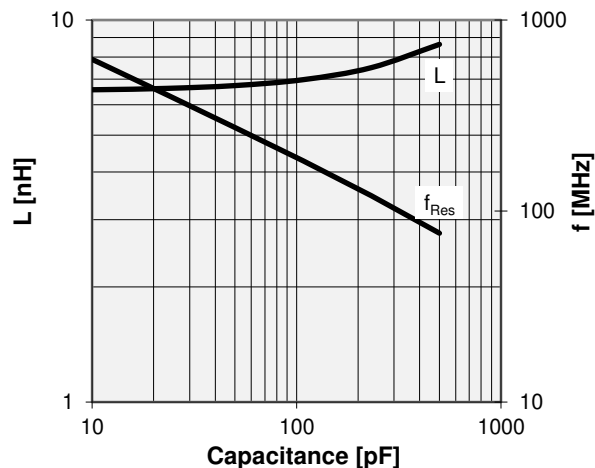

<b>Special Features:</b>
Opti-Cap 2000, Integrated Flange

<b>Type Ordering Information:</b>	<b>Upt</b>
CVBA-500BC/5-DEA-CL	5 kV

Note:  
 Technical information in Service Bulletins  
 SB-32 and SB-52 must be considered  
 Subject to change without prior notice