

YC-179 / YC-179A HIGH-MU POWER TRIODE

The Eimac YC-179 is a ceramic/metal high-mu power triode designed for pulsed rf applications. Utilizing beam-forming cathode and control grid geometry, this tube provides the gain of a tetrode with circuit advantages and simplified design of a triode. The attributes of high gain, low grid interception and outstanding intermodulation performance make this tube well suited for applications such as MRI or for pulsed linear amplifier service.

The YC-179 is rated for pulsed rf amplifier service at a maximum plate voltage of 6500 Vdc. This tube is also useful in pulse modulator or pulse regulator service where accurately controlled waveforms are required; in this service the maximum rated plate voltage holdoff is 13 kVdc. The peak plate current rating in either service is 67 amperes.

The anode is forced-air cooled for 5000 watts of dissipation. The tube does not require a socket.

The YC-179A is identical to the YC-179 except for the mounting hardware.



CHARACTERISTICS¹

ELECTRICAL

Filament: Oxide Coated, Unipotential

Voltage	15.0 ± 0.75	V
Current at 15.0 Volts	15.0	A
Minimum Warm-up Time: (before application of rf drive and high voltage)	6	Min

Direct Interelectrode Capacitances (grounded grid)²

Cin	92.5	pF
Cout	36.2	pF
Cpk	0.35	pF

Amplification Factor (approximate)	200
Frequency of Maximum Ratings (CW) (pulsed RF service)	150 MHz

MECHANICAL:

Maximum Dimensions:

Length	8.25 in; 20.96 mm
Diameter	4.94 in; 12.55 mm
Weight (approx.)	9.5 lbs. 4.3 kg

Operating Position: Vertical, Base Up or Down

Maximum Operating Temperature:

Ceramic/Metal Seals	250° C
Anode Core	250° C

Cooling: Forced Air

Base: Designed for Direct Chassis Mounting

Socket: None Required

Available Chimney: Eimac SK-306

Available Anode Connector Clip: Eimac ACC-3
(for DC, pulse and LF/HF applications)

¹ Characteristics and operating values are based upon performance tests. These figures may change without notice as the result of additional data or product refinement. CPI Eimac Division should be consulted before using this information for final equipment design.

² Capacitance values are for a cold tube as measured in a special shielded fixture in accordance with Electronic Industries Association Standard RS-191.

RANGE VALUES FOR EQUIPMENT DESIGN

	Min.	Max.	
Cathode Warm-Up Time	6	---	Minutes
Interelectrode Capacitances¹ (grounded grid connection)			
Cin	88.0	100.0	pF
Cout	28.0	42.0	pF
Cpk	---	0.50	pF

¹ Capacitance values are for a cold tube as measured in a shielded fixture in accordance with Electronic Industries Association Standard RS-191.

The values listed above represent specified limits for the product and are subject to change. The data should be used for basic information only. Formal, controlled specifications may be obtained from CPI for use in equipment design.



For information on this and other CPI products, visit our website at: www.cpii.com,
or contact: CPI MPP, Eimac Operation, 607 Hansen Way, Palo Alto, CA 94303
TELEPHONE: 1(800) 414-8823. **FAX:** (650) 846-3795 | **EMAIL:** powergrid@cpii.com

YC-179 / YC-179A HIGH-MU POWER TRIODE



PULSED RADIO FREQUENCY AMPLIFIER, CATHODE DRIVEN, Class B

ABSOLUTE MAXIMUM RATINGS:

DC Plate Voltage	6500 Volts
Peak Plate Current ²	67 Amperes
DC Plate Current	3.75 Amperes
Plate Dissipation	5000 Watts
DC Grid Current	±0.10 Amperes
Instantaneous Grid/Cathode Voltage	560 Volts
Grid Dissipation	25 Watts

¹ Approximate value

² Average during the pulse

³ Estimated Value

TYPICAL OPERATION - (Measured Data at 50 MHz)

Plate Voltage	6400 Vdc
Cathode Bias Voltage	+80 Vdc
Pulse Plate Current ²	16.25 Adc
Pulse Power Input ²	104 kW
Pulse Grid Current ^{1,2}	600 mA
Peak Driving Power ^{1,2}	5.6 kW
Peak (Useful) Power Output ^{2,3}	63 kW
Cathode Input Impedance	16.6 Ohms
Resonant Load Impedance	204 Ohms
Power Gain	10.5 dB

PULSED RADIO FREQUENCY POWER AMPLIFIER Cathode Driven, Class AB Service

ABSOLUTE MAXIMUM RATINGS:

DC Plate Voltage	6.5 Kilovolts
Peak Plate Current ²	67 Amperes
DC Plate Current	3.75 Amperes
Plate Dissipation ²	5.0 Kilowatts
DC Grid Current	± 0.1 Ampere
Instantaneous Grid/Cathode Voltage	560 Volts
Grid Dissipation	25 Watts

¹ Approximate value

² Average during the pulse

³ Power delivered to the load

NOTES:

- Pulse length, pulse plate current and duty are interrelated; see Derating Chart.

- To prevent excessive anode dissipation, the tube must be cut off between pulses; a bias switching scheme should be employed to accomplish this. IMD is that of a similar product in CW service.

TYPICAL OPERATION , to 30 MHz (measured data)

Plate Voltage	5.5	6.0	Vdc
Zero Signal Plate Current	0.5	0.75	Adc
Pulse Plate Current ²	3.9	5.25	A
Cathode Bias	+33	+30	Vdc
Pulse Grid Current ^{1,2}	30	40	ma
Peak Driving Power ¹	425	750	W
Pulse Power Output ^{2,3}	14	20	kW
Power Gain	15	14.2	dB
Cathode Load Impedance	23	19	Ohms
Resonant Load Impedance	1100	600	Ohms
Intermodulation Distortion:			
3rd Order Products	-33	-30	dB
5th Order Products	-38	-35	dB

PULSED MODULATOR OR SWITCH TUBE SERVICE

ABSOLUTE MAXIMUM RATINGS:

DC Plate Voltage	13 Kilovolts
Peak Plate Current ²	67 Amperes
Pulse Duration & Duty ²	See Derating Chart
Plate Dissipation	5 Kilowatts
DC Grid Voltage	-250 Volts
Grid Dissipation	25 Watts
DC Grid Current	±0.1 Ampere

¹ Approximate value

² Pulse length, pulse plate current and duty are interrelated; see Derating Chart.

TYPICAL OPERATION – Pulse Modulator Service

Plate Voltage	8.0 kVdc
Pulse Plate Current	50 A
Grid Bias Voltage	-110 Vdc
Pulse Positive Grid Voltage	240 V
Pulse Grid Current ¹	1.0 A
Pulse Duration	10 μs
Duty	0.06 %
Pulse Driving Power ¹	350 W
Pulse Output Power ¹	300 kW
Pulse Output voltage	6.0 kV



YC-179 / YC-179A HIGH-MU POWER TRIODE

NOTE: TYPICAL OPERATION data are obtained from direct measurement or by calculation from published characteristic curves. Adjustment of the rf grid voltage (feedback) to obtain the specified anode current at the specified bias and anode voltages is assumed. If this procedure is followed, there will be little variation in output power when the tube is changed.

APPLICATION

MECHANICAL

MOUNTING - The YC-179 and YC-179A should be mounted vertically, base up or down, and should be protected from vibration and shock. The tube is designed to be bolted directly to the chassis (by the grid flange) in equipment designed for dc and rf grounded grid circuit configuration. The mounting may be insulated for other circuitry. A flange with threaded holes is provided for a low-inductance cathode connection. A similar provision is made for the heater connection.

STORAGE - If a tube is to be stored as a spare it should be kept in its original shipping carton, with the original packing material, to minimize the possibility of handling damage.

COOLING - Forced-air cooling must be provided to maintain the anode core and seal temperatures at a safe temperature. Data shown are for cooling air at 25°C, 35°C and 50°C, summarizing minimum requirements to limit tube temperatures to 225°C. The pressure drop figures are approximate.

INLET AIR TEMPERATURE = 25°C

Plate Dissipation (kW)	SEA LEVEL		5,000 FEET		10,000 FEET	
	Air Flow (CFM)	Pressure Drop (In. H2O)	Air Flow (CFM)	Pressure Drop (In. H2O)	Air Flow (CFM)	Pressure Drop (In. H2O)
2,000	30	0.1	35	0.1	45	0.1
3,000	65	0.3	75	0.3	95	0.4
4,000	115	0.8	140	0.9	165	1.0
5,000	210	2.2	220	2.0	265	2.3

INLET AIR TEMPERATURE = 35°C

Plate Dissipation (kW)	SEA LEVEL		5,000 FEET		10,000 FEET	
	Air Flow (CFM)	Pressure Drop (In. H2O)	Air Flow (CFM)	Pressure Drop (In. H2O)	Air Flow (CFM)	Pressure Drop (In. H2O)
2,000	35	0.1	40	0.1	50	0.1
3,000	75	0.3	90	0.4	105	0.4
4,000	130	0.9	160	1.1	190	1.3
5,000	2180	1.7	255	2.5	305	3.0

INLET AIR TEMPERATURE = 50°C

Plate Dissipation (kW)	SEA LEVEL		5,000 FEET		10,000 FEET	
	Air Flow (CFM)	Pressure Drop (In. H2O)	Air Flow (CFM)	Pressure Drop (In. H2O)	Air Flow (CFM)	Pressure Drop (In. H2O)
2,000	40	0.1	50	0.1	60	0.1
3,000	90	0.5	110	0.5	135	0.4
4,000	165	1.3	200	1.6	240	1.0
5,000	260	3.1	315	3.7	385	4.3

It is considered good engineering practice to design for a maximum anode core temperature of 225°C, and temperature-sensitive paints are available for checking base and seal temperatures before any design is finalized. It is also considered good practice to allow for variables such as dirty air filters, rf seal heating, and the fact that the anode cooling fins may not be clean if the tube has been in service for some length of time. Eimac Application Bulletin #20 titled TEMPERATURE MEASUREMENTS WITH EIMAC TUBES discusses this subject and is available on request.

Forced air cooling of the base is also required, with air directed past the seal areas. An air interlock system should be used to automatically remove all voltages from the tube in case of even partial failure of the tube cooling air. Airflow must be applied

YC-179 / YC-179A

HIGH-MU POWER TRIODE



before or simultaneously with the application of power, including the tube heater, and should normally be maintained for several minutes after power is removed for tube cool-down.

ELECTRICAL

ABSOLUTE MAXIMUM RATINGS - Values shown for each type of service are based on the "absolute system" and are not to be exceeded under any service conditions. These ratings are limiting values outside which serviceability of the tube may be impaired. In order not to exceed absolute ratings the equipment designer has the responsibility of determining an average design value for each rating below the absolute value of that rating by a safety factor so that the absolute values will never be exceeded under any usual conditions of supply-voltage variation, load variation, or manufacturing variation in the equipment itself. It does not necessarily follow that combinations of absolute maximum ratings can be attained simultaneously.

HIGH VOLTAGE – Normal operating voltages used with this tube are deadly. Equipment must be designed properly and operating precautions must be followed. Equipment must be designed so that no one can come in contact with high voltages. All equipment must include safety enclosures for high-voltage circuits and terminals, with interlock switches to open the primary circuits of the power supplies and to discharge high-voltage condensers whenever access doors are opened. Interlock switches must not be bypassed or "cheated" to allow operation with access doors open. Always remember that **HIGH VOLTAGE CAN KILL**.

For pulse modulator or regulator service anode voltage should not exceed 13 kVdc at sea level. This value assumes some safety factor and assumes a clean tube with no buildup of dirt or grime across the insulating ceramic. At higher altitudes a reduction in voltage may be required to preclude the possibility of external tube flashover.

HEATER/CATHODE OPERATION – Rated heater voltage for the YC-179 and YC-179A is 15.0 volts, as measured at the base of the tube, and short-term variations should be limited to ± 0.75 volt for good life and consistent performance.

Pulse current capability of the YC-179 and YC-179A is dependent on cathode temperature, which in turn is dependent on heater voltage. For most consistent performance in switch tube or modulator service, regulation of the heater voltage to limit variation to plus/minus one percent is recommended. Heater voltage should be measured with a known accurate rms-responding meter

This tube is designed for normal commercial service, where one filament on/off cycle is anticipated per day. Contact Eimac ApplicationEngineering if more daily on/off cycles are expected.

CATHODE WARMUP/COOLDOWN TIME – It is recommended that heater voltage be applied for a minimum of 6 minutes before anode voltage and drive voltage are applied, to allow for proper conditioning of the cathode surface. It is also recommended that after all voltages are removed from the tube that air cooling be allowed to run for several minutes to allow for proper cool down.

INPUT CIRCUIT: When operated as a grounded-grid rf amplifier, the use of a resonant tank in the cathode circuit is recommended to obtain greatest linearity and power output. For best results with a singled-ended amplifier it is suggested the cathode tank circuit operate at a "Q" of 3 or more.

GRID OPERATION – The maximum rated dc grid bias voltage for the tube is -250 volts and the maximum grid dissipation is 25 watts. The maximum instantaneous grid/cathode voltage must not exceed 425 volts, and average grid current should never exceed 100 mAdc.

In normal applications the grid dissipation will not approach the maximum rating. In applications where pulse duration exceeds 100mS or duty factor is high, the electrode dissipation ratings may prevent attaining peak anode current substantially over the dc rating.

Oxide cathode tubes may exhibit reverse grid current. Protective circuitry for detection of overload and fault conditions should be capable of accepting current flow in either direction. This type of circuitry is necessary to prevent excessive grid dissipation and resulting tube degradation which can occur if proper output (anode) tuning or loading is lost due to failure in the tuned circuit or failure in the load.

A protective spark gap such as the Siemens #B1-C145 connected between the cathode and grid will help protect the tube in the event of an internal arc. A maximum of four (4) joules total energy may be permitted to dissipate into a grid-cathode arc. Amounts in excess of this will permanently damage the cathode or grid structure. Additional information is given in Eimac Application Bulletin #17 titled **FAULT PRO-TECTION**, available on request.

CW OPERATION – Normal Class C operation is not permitted. Operation should be restricted to Class A, AB and B service. Operation in pulsed Class C is permissible only with low duty and short duration service.

ANODE CURRENT - For pulsed service, a peak anode current (during the pulse) of up to 67 amperes is available. Peak current capability, pulse length, and duty factor are interrelated and the Pulse Derating Chart should be consulted. To use this chart, enter with pulse duration and note the intersection with the



YC-179 / YC-179A

HIGH-MU POWER TRIODE

desired pulse anode current. At this intersection read off values of maximum duty and/or pulse repetition rate.

The pulse derating chart is intended to allow selection of operating parameters which give a reasonable tube life. Operating under experimental combinations of maximum plate current and pulse duration which are outside the ranges of the chart may give useful results at low repetition rates, with a resulting tube life commensurate with that type of operation.

New designs using tubes in pulse applications should include consideration of tube-to-tube performance variations which may effect equipment performance.

ANODE OPERATION – The anode of the YC-179 and YC-179A is nominally rated for 5000 watts with forced-air cooling. In pulsed service the average anode dissipation may be calculated as the product of pulse anode current, pulse tube-voltage drop during conduction, and the duty factor. Actual dissipation may often exceed the calculated value, if pulse rise and fall times are appreciable compared to pulse duration. This occurs because long rise and fall times allow anode current to flow for longer periods in the high tube-voltage drop region.

X-RADIATION HAZARD – High vacuum tubes operating at voltages higher than about 10 kilovolts produce progressively more dangerous X-ray radiation as the voltage is increased. The YC-179 and YC-179A, operating at its rated voltages and currents, is a potential X-ray hazard, with only limited shielding afforded by the tube envelope. Moreover, the X-ray radiation level can increase significantly with aging and gradual deterioration, due to leakage paths or emission characteristics as they are affected by the high voltage. X-ray shielding must be provided on all sides of tubes operating at these voltages to provide adequate protection throughout the tube's life. Periodic checks on the X-ray level should be made and the tube should never be operated without adequate shielding in place when voltages above 10 kilovolts are in use. Lead glass, which attenuates X-rays, is available for viewing windows. If there is any doubt as to the requirement for or the adequacy of shielding, an expert in this field should be contacted to perform an X-ray survey of the equipment. Operation of high-voltage equipment with interlock switches "cheated" and cabinet doors open in order to better able to locate an equipment malfunction can result in serious X-ray exposure.

FAULT PROTECTION - All power tubes operate at voltages which can cause severe damage in the event of an arc, especially in cases where large amounts of power supply stored energy are involved. Some means of protection is advised in all cases, and it is imperative that a series resistor be used in the lead from the power supply to the anode circuit to limit peak current and help dissipate the energy in the event of a tube or circuit arc. A resistance of 10 ohms, with at least a 200W rating, in the positive anode power supply lead will help protect the tube in the event of an arc. A crowbar circuit which utilizes a high-speed switch tube is especially recommended for protection of the YC-179 and YC-179A in pulse service.

Energy dissipated in the event of an arc must be limited to no more than 4 joules to prevent damage to the tube and consequential degradation in performance. EIMAC Application Bulletin #17 titled FAULT PROTECTION discusses this subject and is available on request.

VHF OPERATION – Operation at VHF should be conducted with heavy anode loading and the lowest drive power consistent with satisfactory performance. It is preferable to operate at a sacrifice in efficiency to obtain increased tube life. VHF driving power will be greater than the typical values shown on page 2 because of higher circuit losses.

INTERELECTRODE CAPACITANCE - The actual internal interelectrode capacitance of a tube is influenced by many variables in most applications, such as stray capacitance to the chassis, capacitance added by the socket used, stray capacitance between tube terminals, and wiring effects. To control the actual capacitance values within the tube, as the key component involved, the industry and the Military Services use a standard test procedure as described in Electronic Industries Association Standard RS-191. This requires the use of specially constructed test fixtures, which effectively shield all external tube leads from each other and eliminates any capacitance reading to "ground". The test is performed on a cold tube in a special shielded fixture. Other factors being equal, controlling internal tube capacitance in this way normally assures good interchangeability of tubes over a period of time, even when the tube may be made by different manufacturers. The capacitance values shown in the manufacturer's technical data, or test specifications, normally are taken in accordance with Standard RS-191. The equipment designer is therefore cautioned to make allowance for the actual capacitance values which will exist in any normal application. Measurements should be taken with mounting which represents approximate final layout if capacitance values are highly significant in the design.

RF RADIATION - Avoid exposure to strong rf fields even at relatively low frequency. Absorption of rf energy by human tissue is dependent on frequency. Under 300 MHz most of the energy will pass completely through the human body with little attenuation or heating affect. Public health agencies are concerned with the hazard, and the published OSHA (Occupational Safety and Health Administration) or other local recommendations to limit prolonged exposure of rf radiation should be followed.

HOT SURFACES - Air-cooled surfaces and other parts of tubes can reach temperatures of several hundred degrees C and cause serious burns if touched for several minutes after all power is removed.

SPECIAL APPLICATIONS - If it is desired to operate this tube under conditions widely different from those given here, contact the CPI Eimac Division, Palo Alto CA for information and recommendations.

YC-179 / YC-179A

HIGH-MU POWER TRIODE



OPERATING HAZARDS

Proper use and safe operating practices with respect to power tubes are the responsibility of equipment manufacturers and users of such tubes. All persons who work with and are exposed to power tubes, or equipment that utilizes such tubes, must take precautions to protect themselves against possible serious bodily injury. **DO NOT BE CARELESS AROUND SUCH PRODUCTS.**

The operation of this tube may involve the following hazards, any one of which, in the absence of safe operating practices and precautions, could result in serious harm to personnel.

HIGH VOLTAGE – Normal operating voltages can be deadly. Remember that **HIGH VOLTAGE CAN KILL.**

LOW-VOLTAGE HIGH-CURRENT CIRCUITS - Personal jewelry, such as rings, should not be worn when working with filament contacts or connectors as a short circuit can produce very high current and melting, resulting in severe burns.

RF RADIATION – Exposure to strong rf fields should be avoided, even at relatively low frequencies. **CARDIAC PACEMAKERS MAY BE AFFECTED.**

HOT SURFACES – Surfaces of tubes can reach temperatures of several hundred °C and cause serious burns if touched for several minutes after all power is removed.

X-RAY RADIATION – High voltage tubes can produce dangerous and possibly fatal x-rays. If shielding is provided equipment should never be operated without all such shielding in place.

MATERIAL COMPLIANCE - This product and package conforms to the conditions and limitations specified in 49CFR 173.424 for radioactive material, excepted package-instruments or articles, UN2910. In addition, this product and package contains no beryllium oxide (BeO).

Please review the detailed Operating Hazards sheet enclosed with each tube, or request a copy from CPI, Eimac Division Application Engineering at 1-800-414-8823.

PULSE DERATING CHART

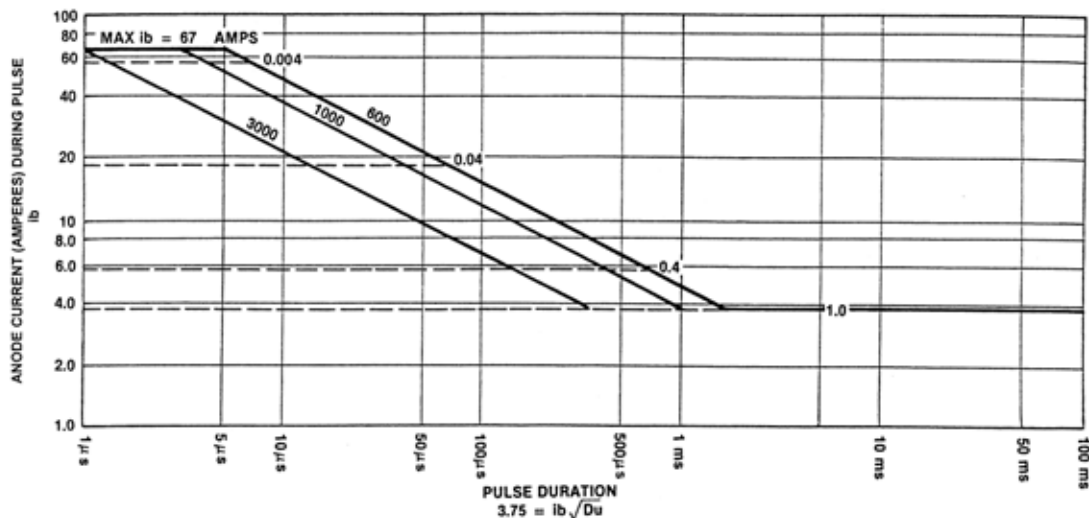

Solid lines represent constant repetition rates. Dashed lines represent constant duties. Do not extrapolate above or to the right of bold lines which set boundaries of maximum anode current and minimum repetition rate, respectively.

Refer to **ANODE CURRENT** section on page 4 for discussion of this chart.

YC-179 / YC-179A HIGH-MU POWER TRIODE

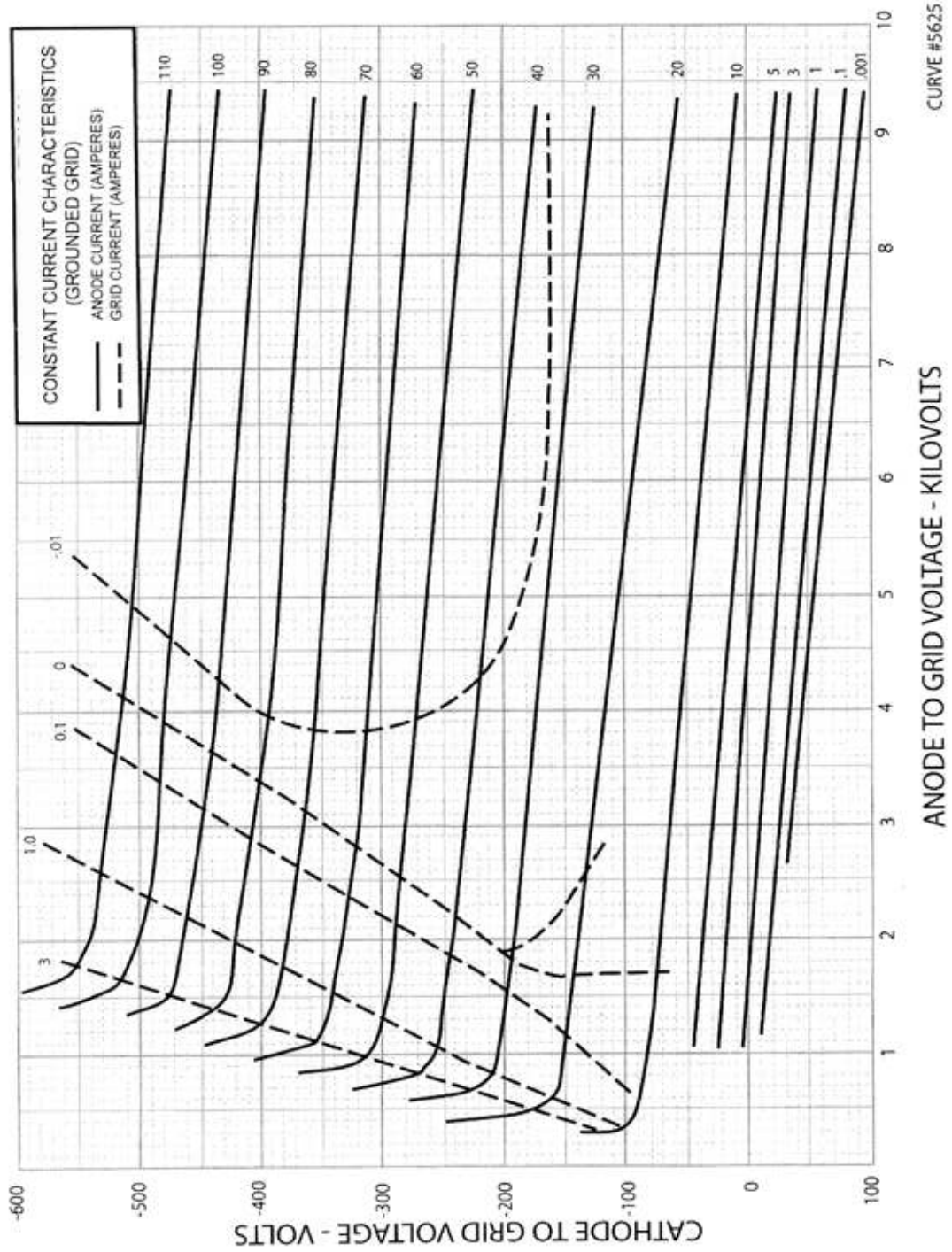

YC-179 / YC-179A HIGH-MU POWER TRIODE



YC-179 Outline Drawing

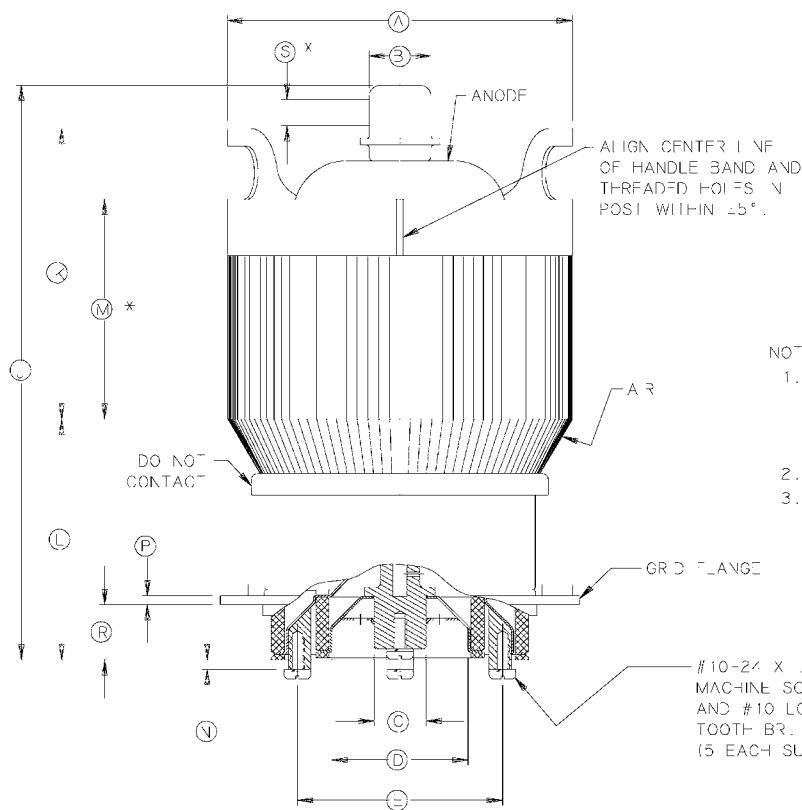

DIMENSIONAL DATA							
INCHES				MILLIMETERS			
DIM.	MIN.	MAX.	REF.	MIN.	MAX.	REF.	
A	4.872	4.938		122.22	125.43		
B	.855	.895		21.72	22.73		
C	.600	.760		15.24	19.30		
D	1.895	1.935		48.16	49.17		
E	2.895	2.935		73.53	74.55		
F	4.425	4.445		112.40	112.90		
G	5.030	5.090		127.76	129.29		
H			265				6.73
J	8.077	8.267		203.63	209.98		
K	3.925	4.299		99.70	109.19		
L	3.223	3.597		81.86	91.36		
M	2.925	3.299		74.30	83.79		
N	.093	.156		2.36	3.96		3.18
P	.72	.845	.125	18.3	21.46		
R	.375			9.53			
S							

NOTES:

1. REF. DIMENSIONS ARE FOR INFORMATION ONLY AND ARE NOT REQUIRED FOR INSPECTION PURPOSES.
2. (x) CONTACT SURFACE
3. FLANGE, THREADED HOLES AND HANDLE BAND ALL TO BE ALIGNED WITHIN ±5°.

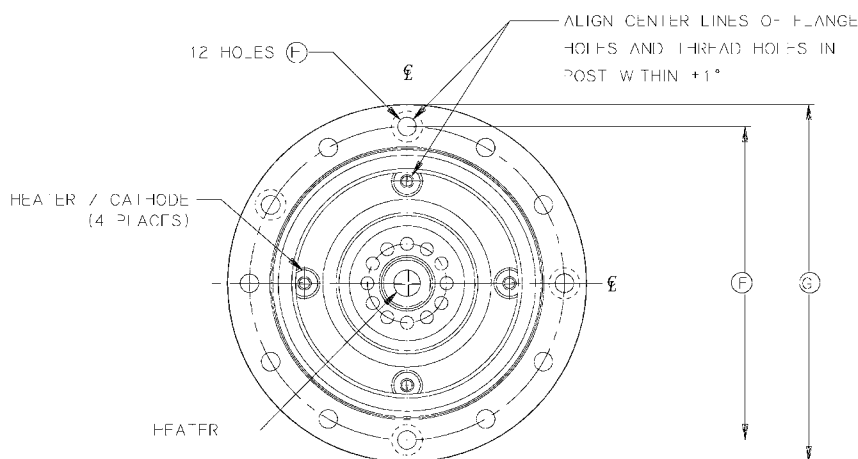

Eimac		This document is the property of Eimac and should not be copied, reproduced, loaned, or otherwise disseminated in any form without the written permission of Eimac.	
Div. of CPI		PART NO. YC179	
OUTLINE		SCALE: 100% 1:1	
ELECTRON DEVICE			
NO. YC179		C	

YC-179A Outline Drawing

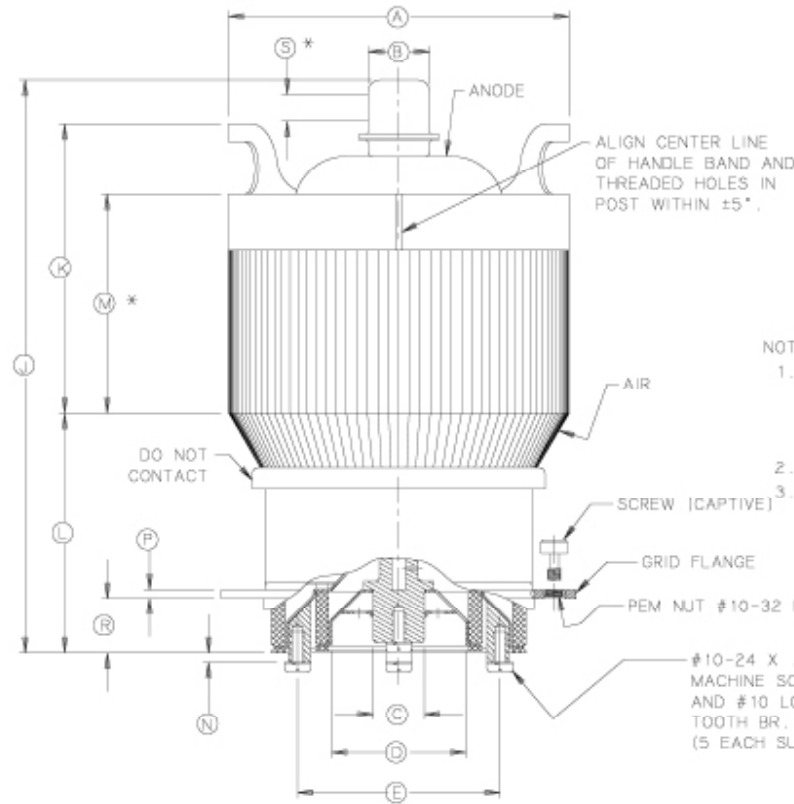

DIMENSIONAL DATA							
INCHES				MILLIMETERS			
DIM.	MIN.	MAX.	REF.	MIN.	MAX.	REF.	
A	4.812	4.938		122	221	25.43	
B	.855	.895		21.72	22.73		
C	.652	.752		16.51	19.30		
D	1.896	1.936		48.16	49.17		
E	2.825	2.935		73.53	74.55		
F	4.425	4.445		112.40	112.20		
G	5.030	5.090		127.78	129.29		
H			285				6.73
J	8.017	8.257		203.63	209.98		
K	3.025	4.250		76.70	109.19		
L	3.223	3.557		81.86	91.36		
M	2.925	3.259		74.30	83.79		
N	.093	.156		2.36	3.96		
P			125				3.18
R	.721	.845		18.31	21.46		
S	.375			9.53			

NOTES:

1. REF. DIMENSIONS ARE FOR INFORMATION ONLY AND ARE NOT REQUIRED FOR INSPECTION PURPOSES.
 2. [*] CONTACT SURFACE
 3. FLANGE, THREADED HOLES AND HANDLE BAND ALL TO BE ALIGNED WITHIN ±5°.
- #10-24 X .38 LG. PAN HEAD MACHINE SCREW BRASS NI. PL. AND #10 LOCK WASHER INTERNAL TOOTH BR. NICKEL PL. (5 EACH SUPPLIED)

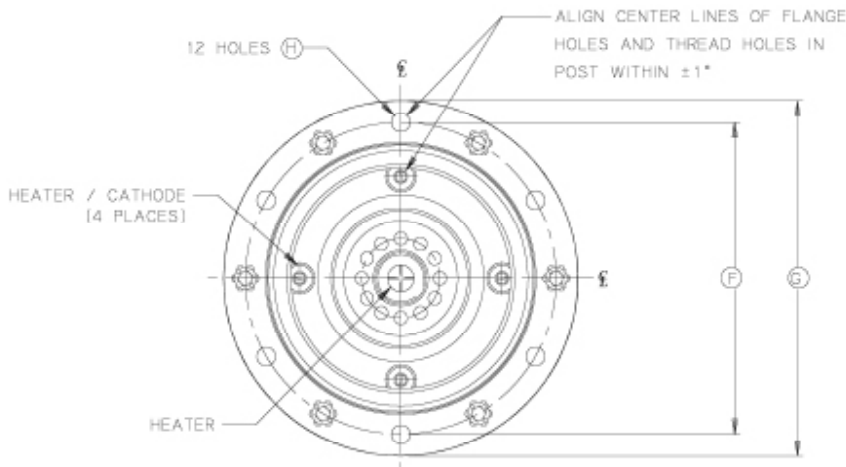

Eimac		This Document is the Property of Eimac and shall not be reprinted, reproduced, used in the manufacture of any type of Apparatus or Equipment without written permission.	
PART NO. YC179A		REV. 001/01	
ELECTRON DEVICE			
NO.	YC179A	B	